

Einstein Telescope

Europe's most advanced observatory for gravitational waves

Science meets industry, science needs industry

Gerjan van de Walle

ET-Vlaanderen

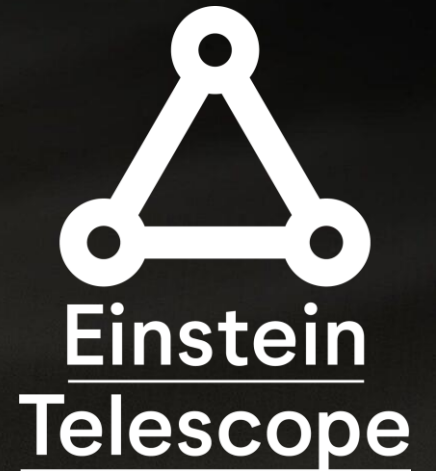

400 years of astronomy

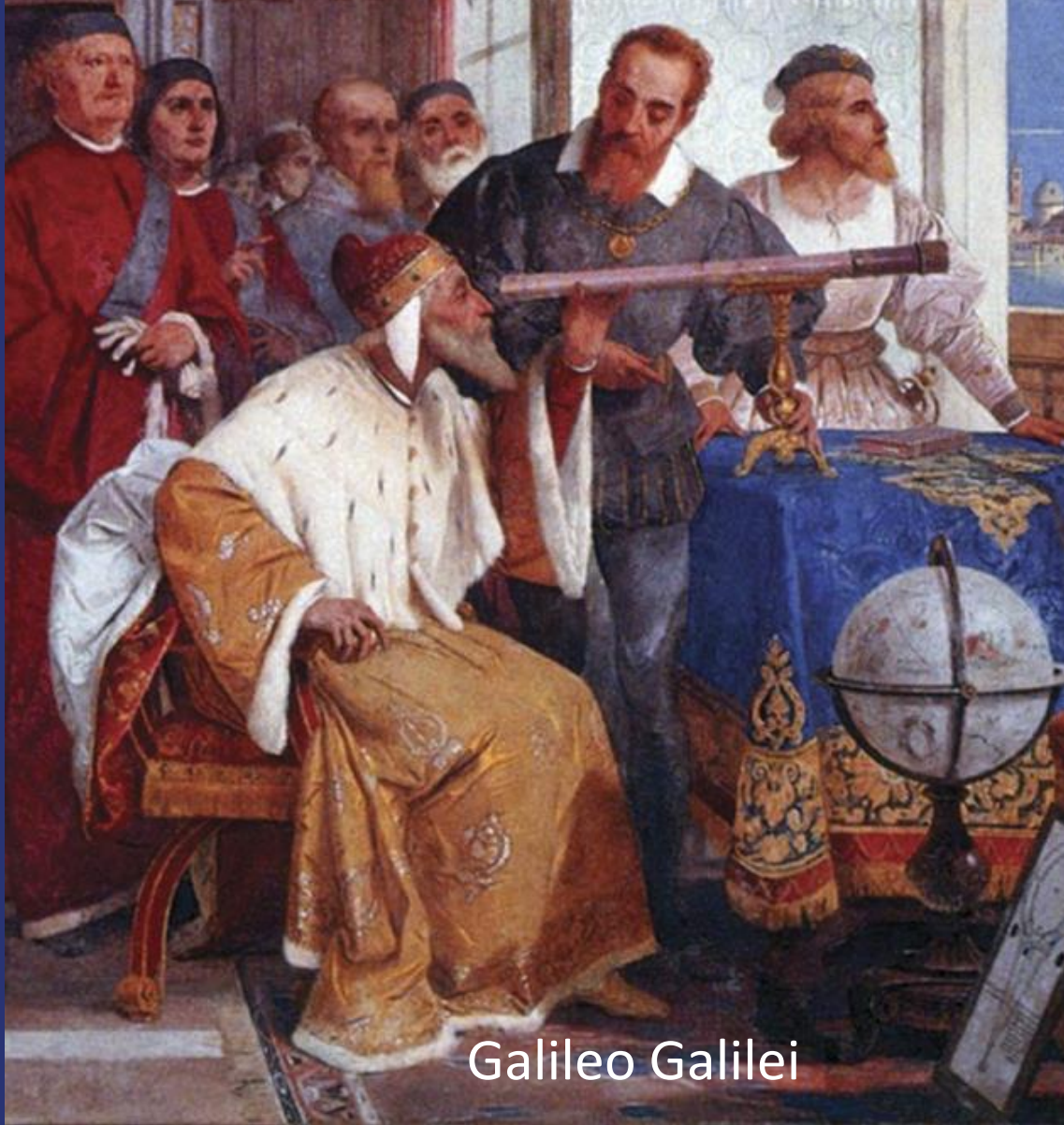

Galileo Galilei



James Webb

NASA

What have we learned?

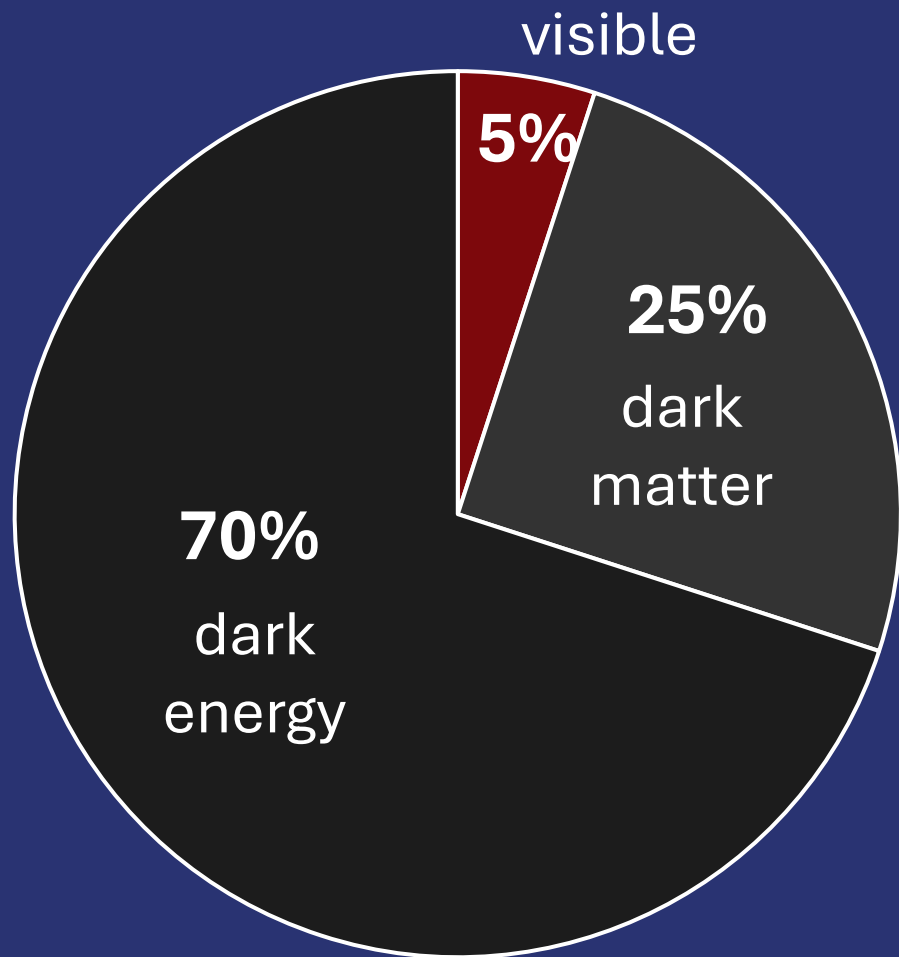

A new era!

14 September 2015

observation of merger
of two black holes

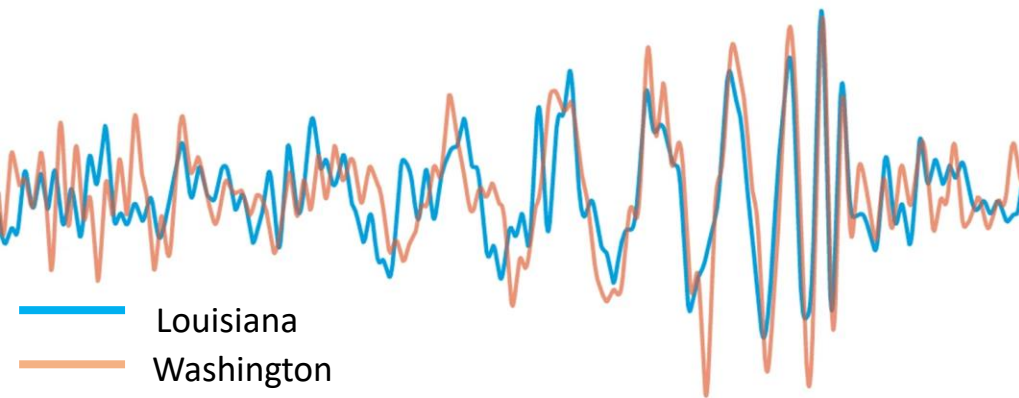
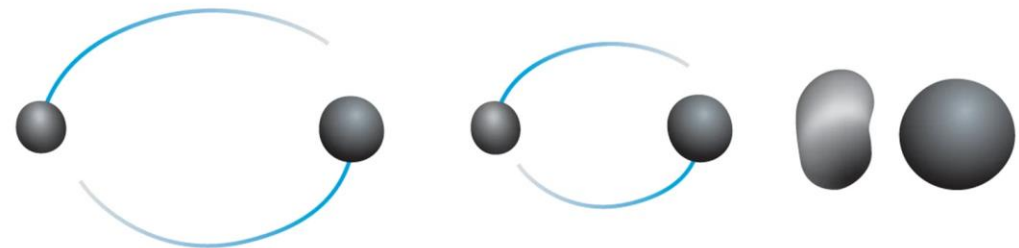

200 ms



Laser Interferometer Gravitational wave Observatory



Einstein's general relativity theory: space and time are 'flexible'

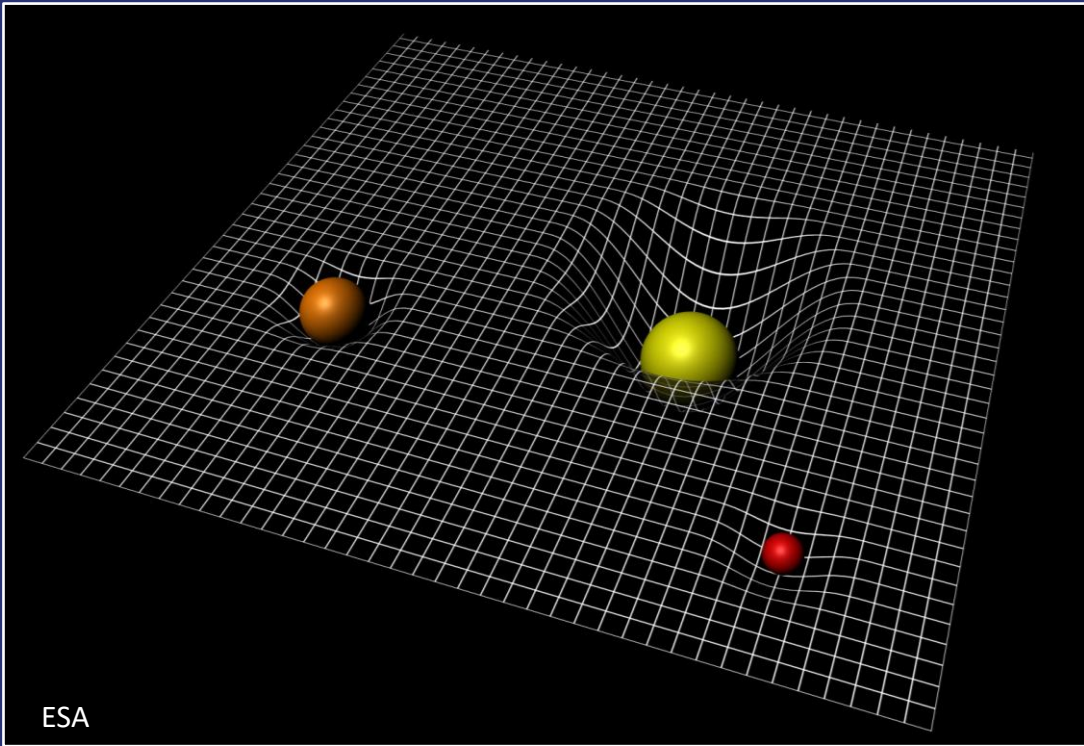

Mass deforms the spacetime fabric and
spacetime dictates the movement of mass

➤ **gravity**

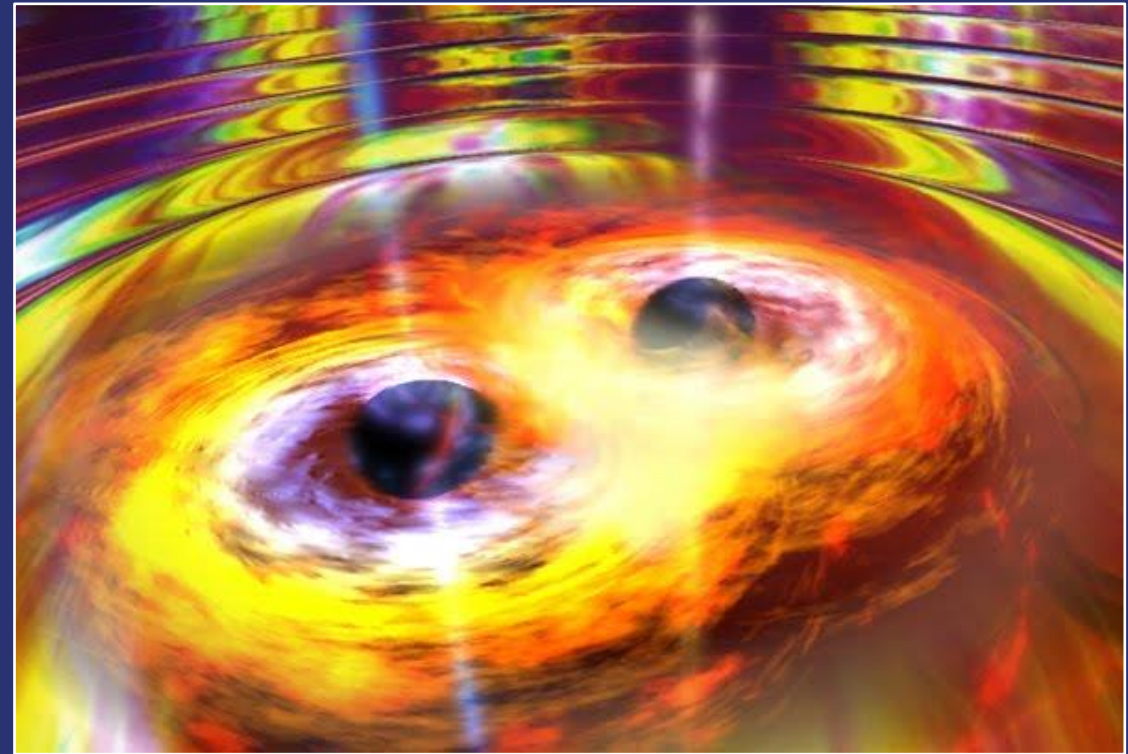

Accelerating masses generate ripples
which propagate through the universe

➤ **gravitational waves**

Detecting gravitational waves

laser
interferometer

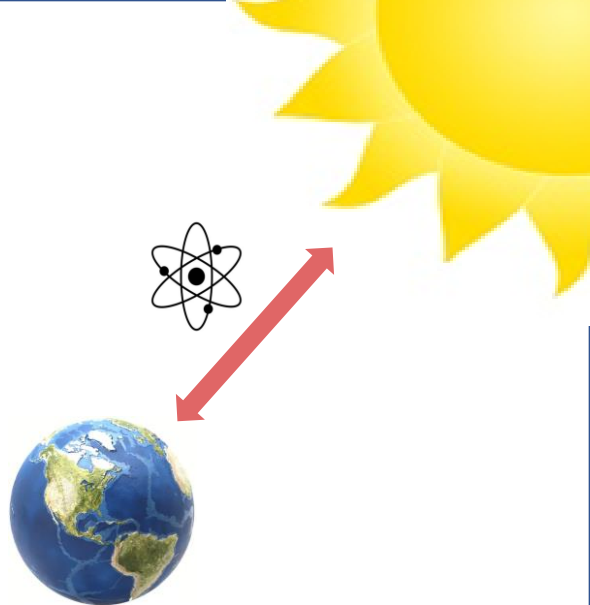
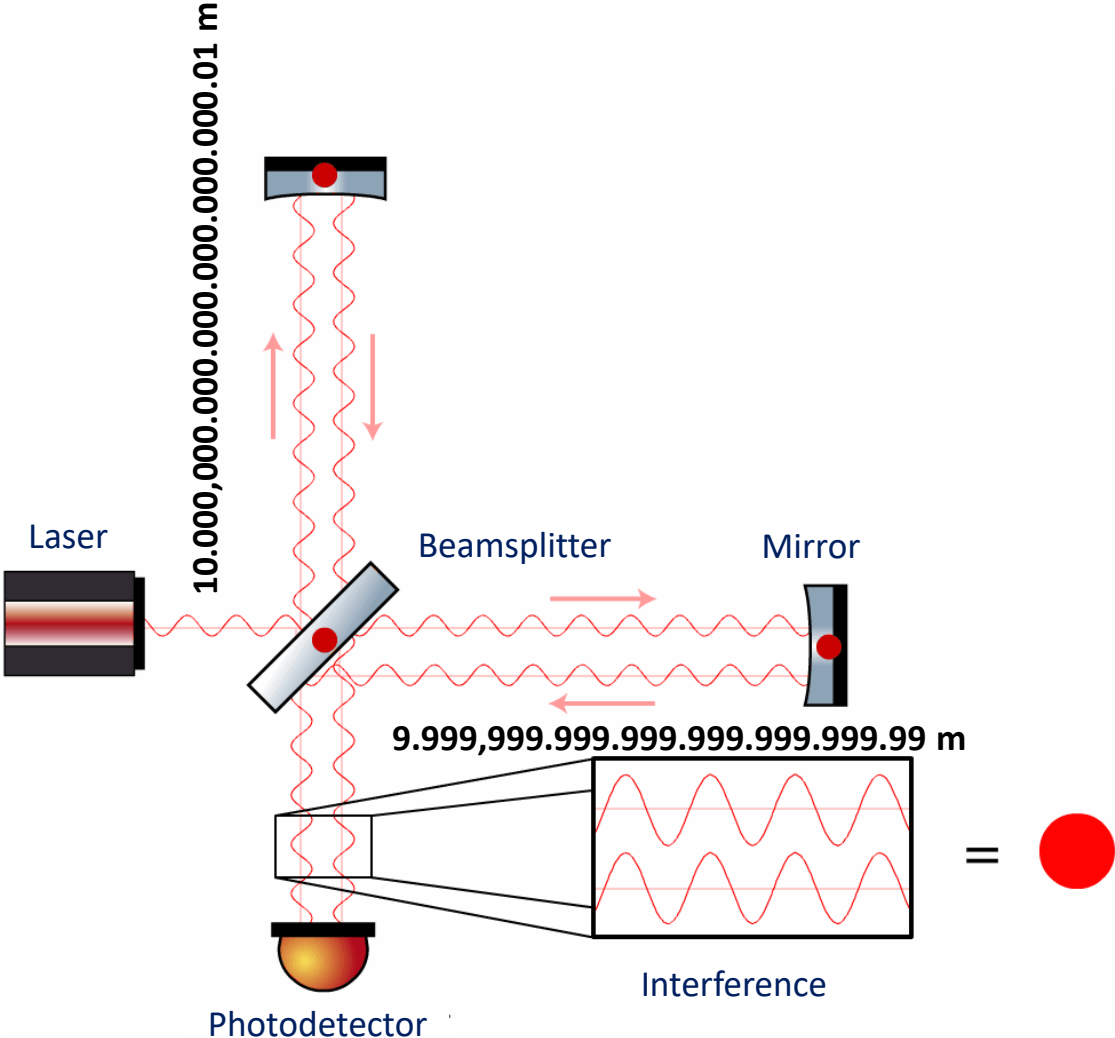

Required sensitivity
 10^{-21} m/m



Today: multiple detectors

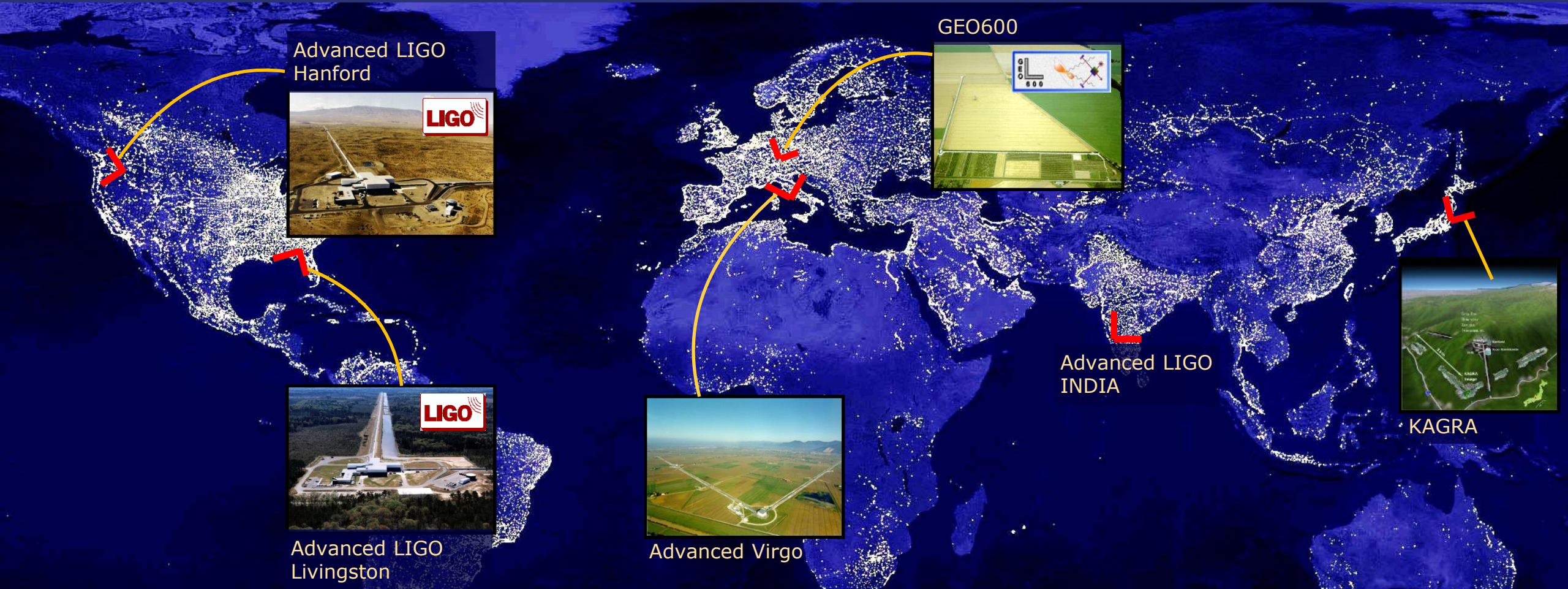

Appr. 3 events/week

Appr. 300 events since 2015



Einstein Telescope

- 10x more sensitive
- 1000x more observations

- Appr. 250 m underground
- Triangle with 10 km arms
- 3 detectors
- 2 interferometers per detector
- Cryogenic mirrors
- 120+ km vacuum pipe

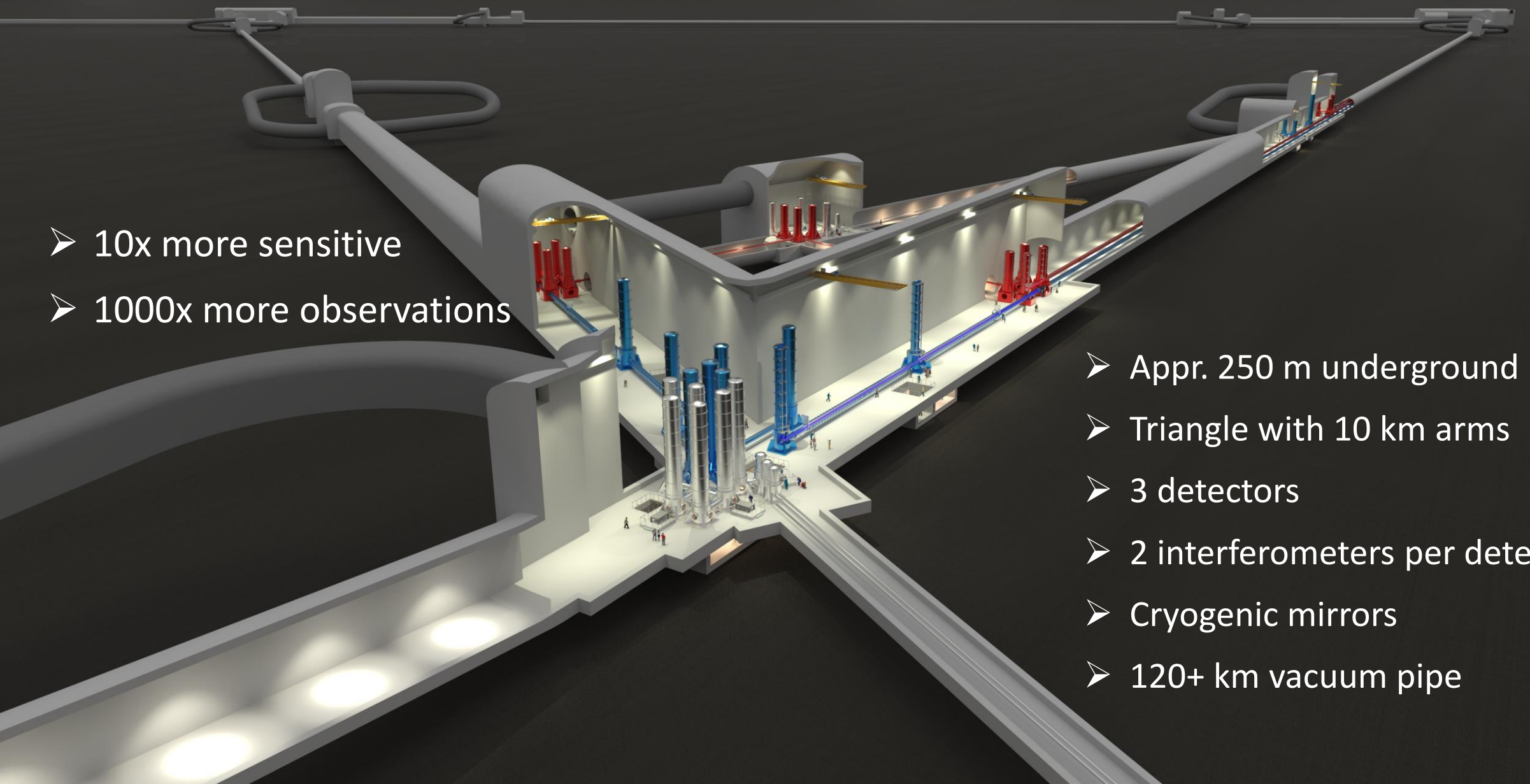

2 interferometers per detector

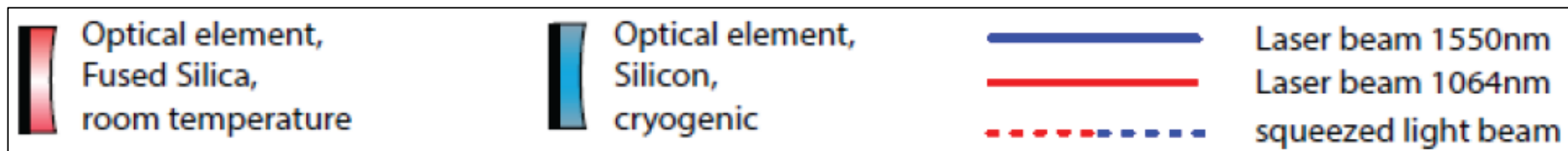
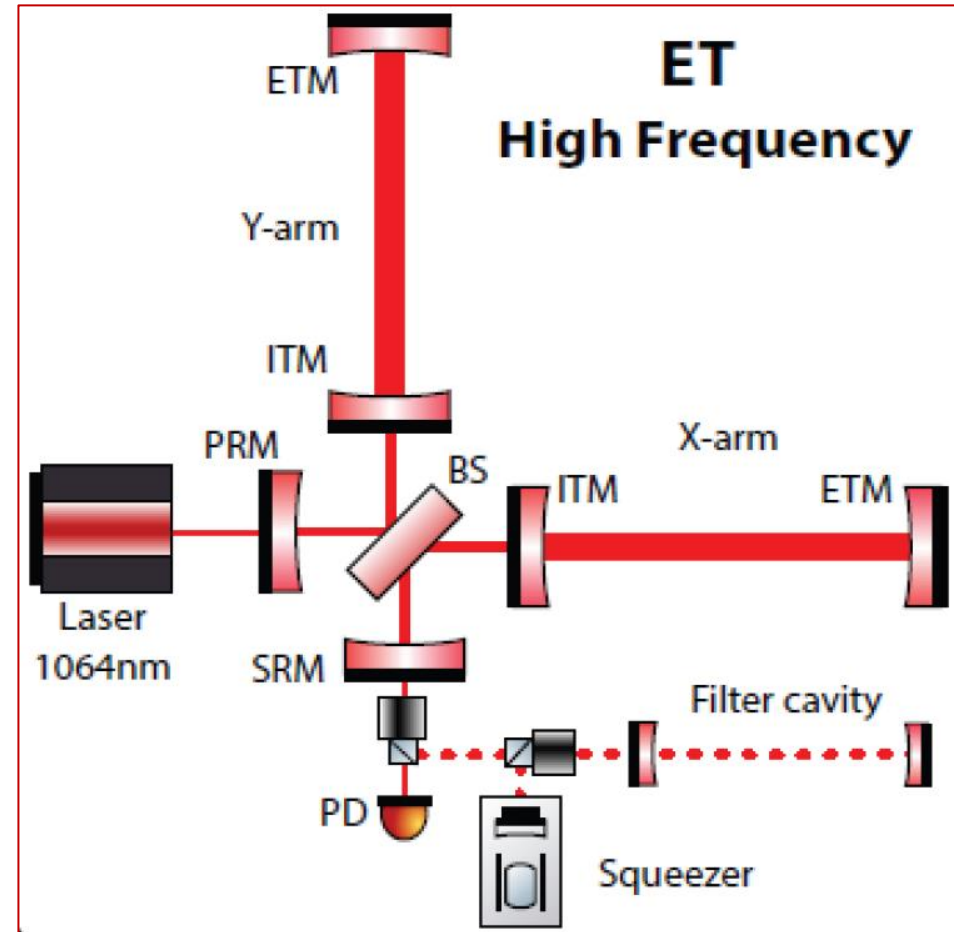
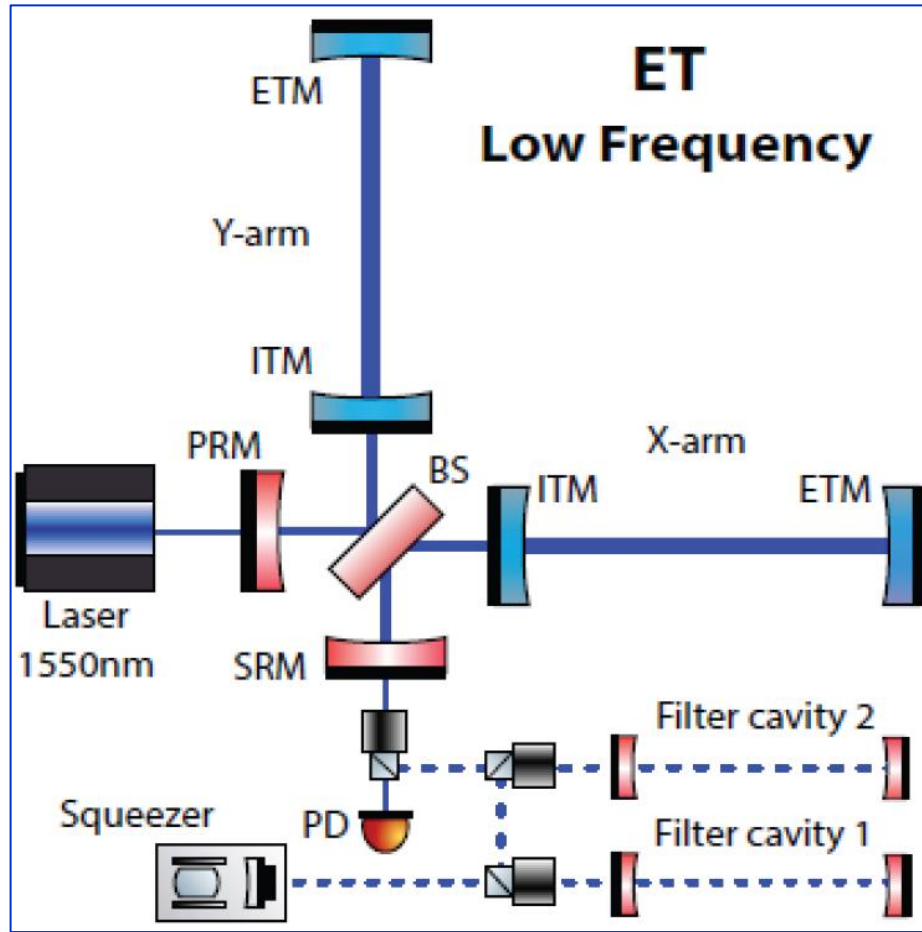

Cavern



Vacuum towers

- Each containing an optical subsystem
 - mirror, laser source, photodetector,
- Vibration damping with multiple stages
 - Inverted pendulum
 - Geometric anti spring dampers
 - Active damping using voice coils
- Cryogenic lower stage for the mirror
- More than 100 towers at each corner



Mirrors

- Single crystal Si
- 45 cm diameter
- Weight appr. 200 kg
- Reflective coatings
- Low temperature (15K)
- RMS roughness < 0.1 nm (~ 1 atom)
- Curved surface
- Suspended with silicon fibers (4 mm diameter)

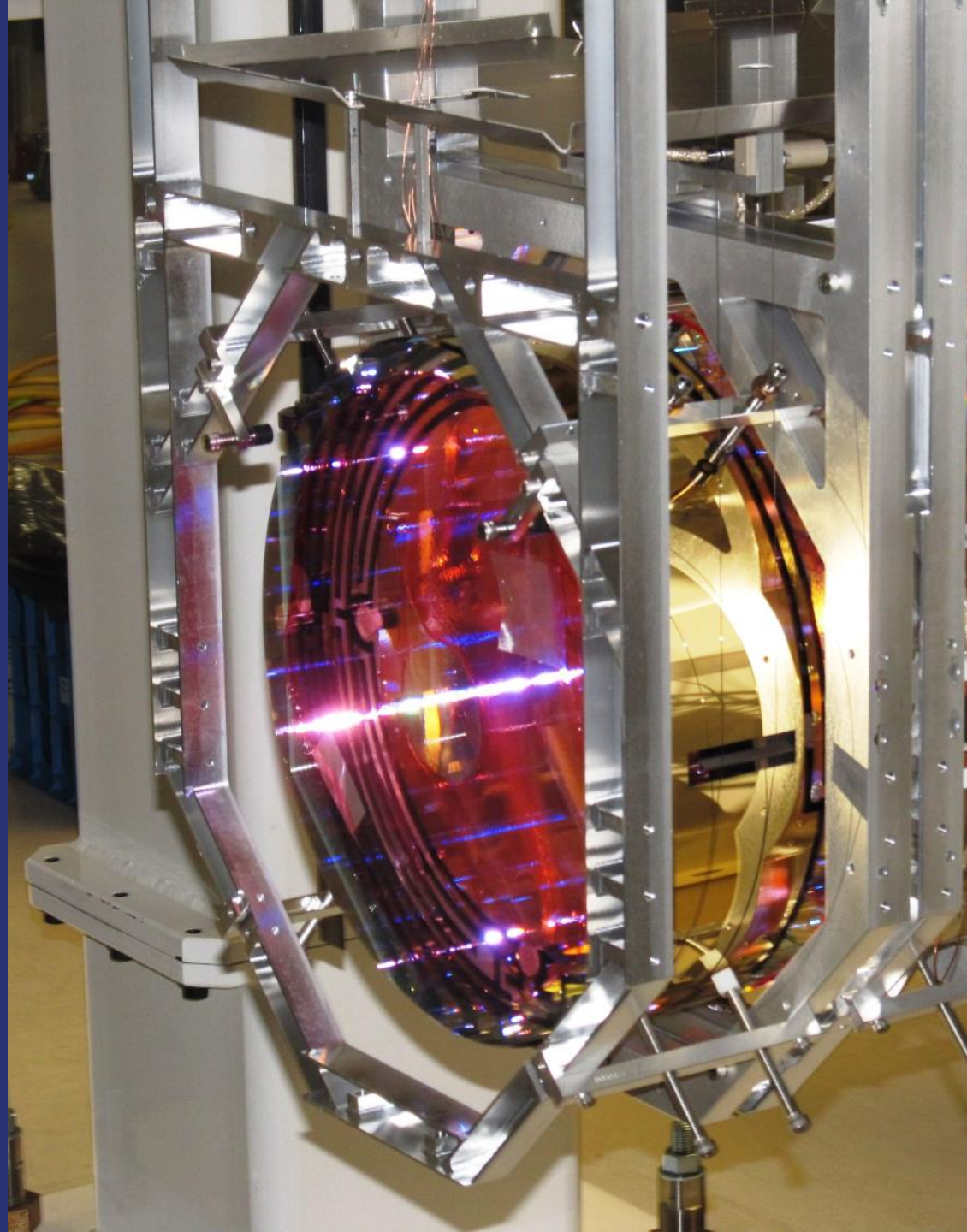

Tunnels

> 30 km tunnel

> 120 km vacuum pipe

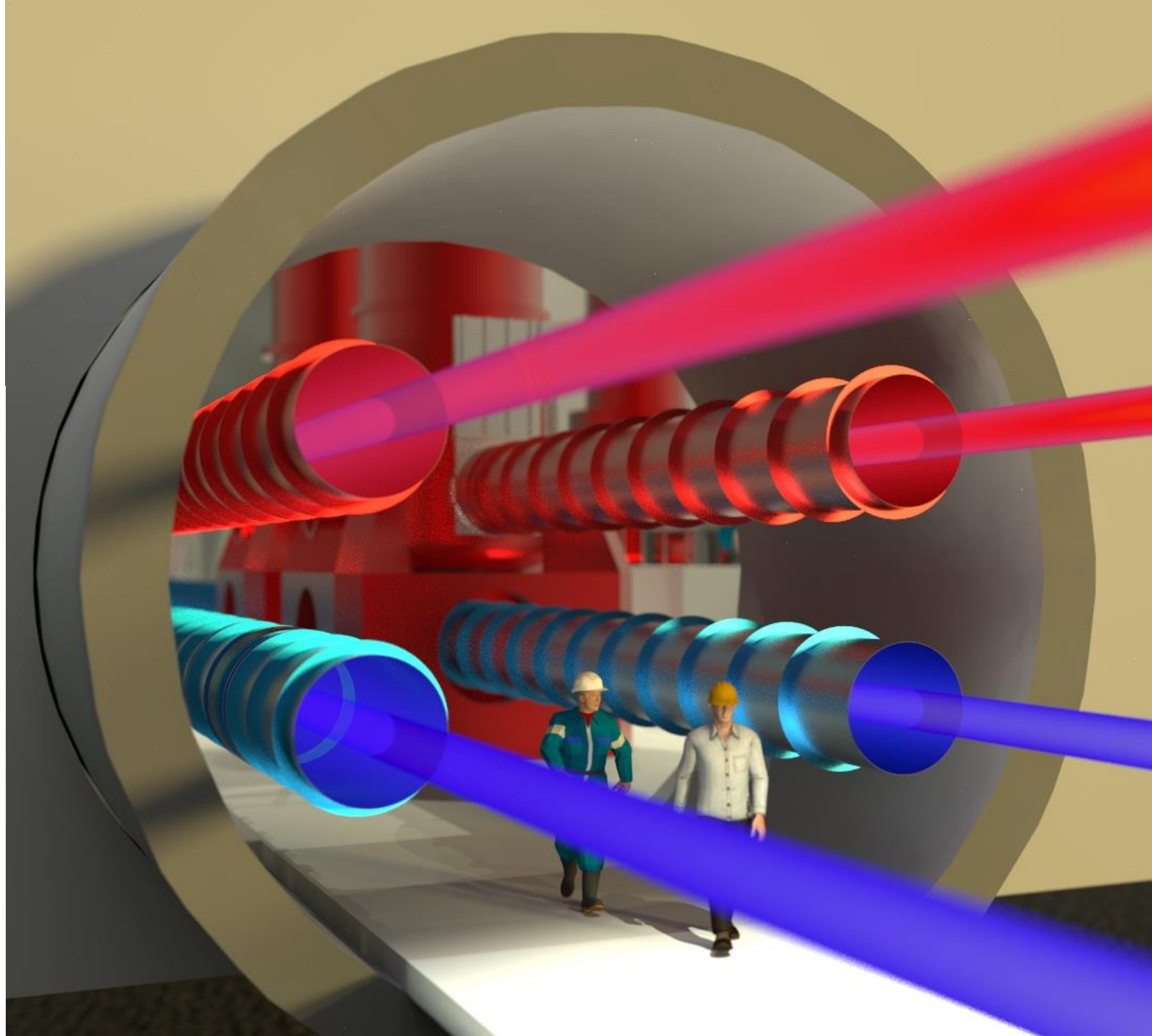
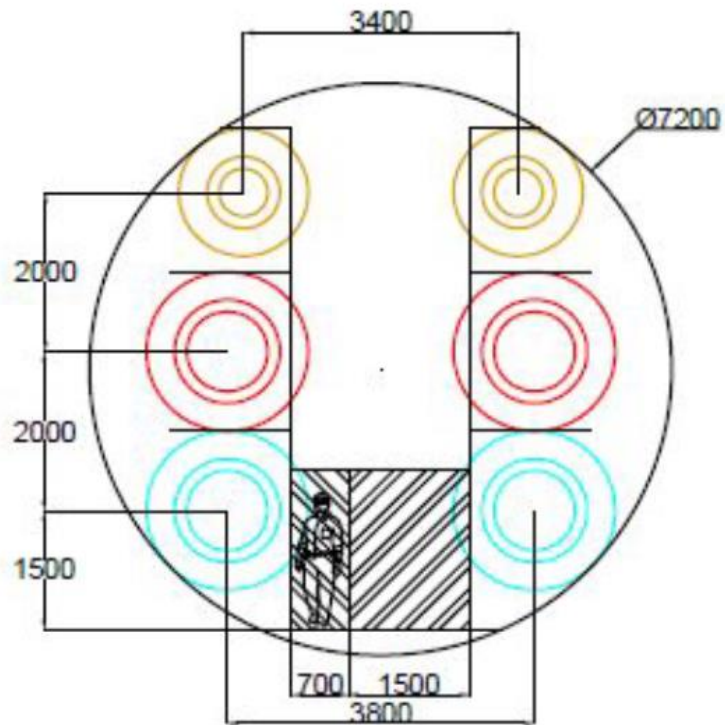

Many technological challenges

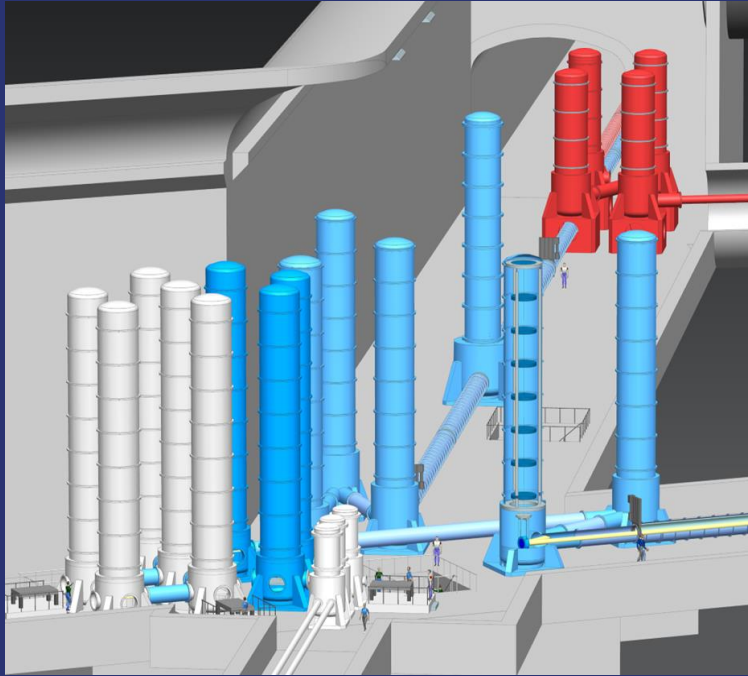

Assembly & test

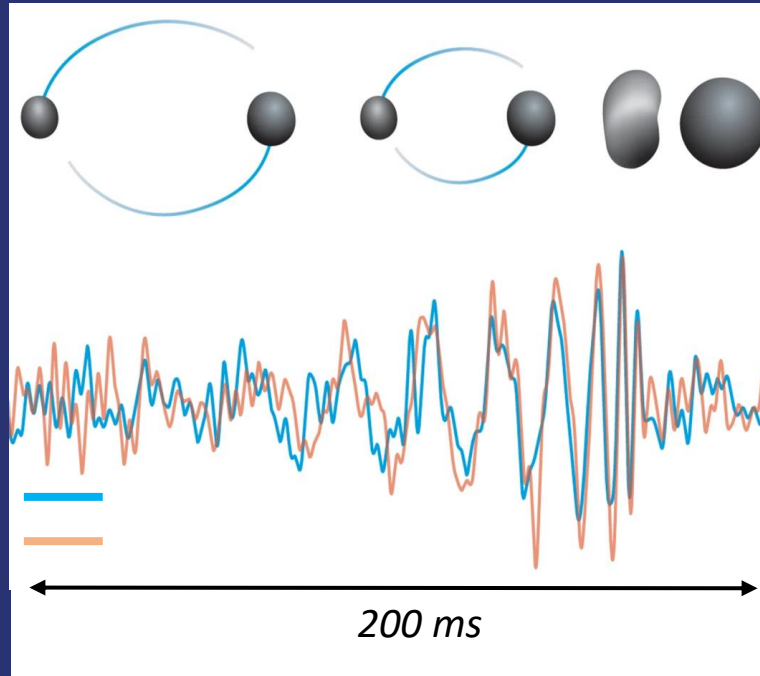

Data analysis



Remote Inspection



ET Pathfinder, Maastricht



Candidate location

Euregion Meuse – Rhein (EMR)

- Favourable geology
- Rural area
- Attractive living environment
- Strong science and industry ecosystem



Curious to learn
more?

Interested to join the
ET ecosystem?

Join the session in the
Skylounge at 13:30 h

Sensor challenges for the Einstein Telescope

Agenda:

- **13:30 h:**
 - Welcome and introduction to the Einstein Telescope project
 - Gerjan van de Walle, Director Business Development, ET-Vlaanderen
- **13:45 h:**
 - Gravitational waves, how to detect these silent messengers from our universe.
 - Hans Van Haevermaet, assistant professor, University of Antwerp
- **14:15 h:**
 - Integrated photonics platform for sensor optical readout: from classical to quantum
 - Xavier Rottenberg, fellow, IMEC
- **14:45 h:**
 - Dialogue and Q&A
- **15:00 h** Closure

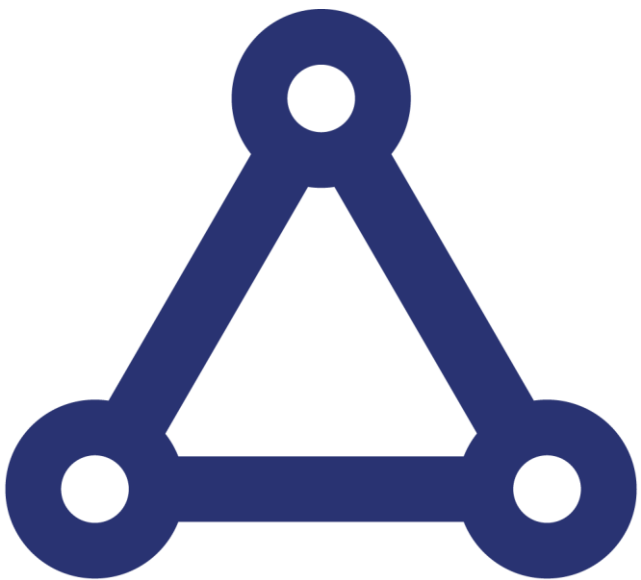

Einstein
Telescope